



### 0-775-26 - 12/24v 7" 2 Channel Split Screen Monitor with fan bracket

Durite's 7" CCTV 2CH Split Screen System. Supplied with Main loom, Sunshade, Fan Bracket and U Shape Steel Bracket. E Marked ECE R10.



## **WARNINGS**

Before using this unit please read these instructions carefully. Take special care to follow the warnings indicated on the unit itself as well as the safety suggestions listed below. Keep these instructions for future reference

**HIGH VOLTAGES WITHIN THIS EQUIPMENT. RISK OF ELECTRIC SHOCK, DO NOT RE-MOVE COVER**

The vehicle safety vision system is designed to be used with, not instead of other viewing aids in your vehicle. The manufacturer shall not be held liable for any accidents which occur while operating this system.

**\* Please ensure you are familiar and comply with local traffic and driving regulations.**

**\* Power Source - The monitor should be connected to a 12 - 24 volt dc power supply only.**

**\* Water and Moisture - Do not use the monitor where it may be subject to water ingress or excessive moisture. Do not use outside the vehicle unprotected.**

**\* Heat - Do not install the monitor or camera near a direct heat sources.**

**\* Ventilation - The monitor should be situated to allow free circulation of air.**

**\* Foreign Material - Care should be taken so that objects do not fall onto or into, and that liquids are not spilled on the monitor.**

**\* Mounting Surface - The monitor should be mounted to a strong secure surface.**

**\* Replacement Parts - Use only manufacturers replacement specified parts. Unauthorised substitutions may result in fire risk, electric shock or other hazards and will void the warranty.**

**\* Service - The user should not attempt to service this units beyond that described in the operating instructions. There are no user-serviceable parts within the unit.**

**\* Isolation - When fitting to an isolated earth vehicle the camera and monitor bracket must also be electrically isolated from the vehicle chassis. If interference is experienced on earthed chassis vehicles electrically isolating the camera from the chassis should eliminate the interference.**

**\* Screen Protective Film - Remove the LCD screen protective plastic cover before use.**

## MONITOR BUTTON LAYOUT

- 1.Power
- 2.CH1
- 3.CH2
- 4.MODE
- 5.MENU
- 6.Increase setting
- 7.Decrease setting



## MONITOR CONNECTIONS

1. CH1/CH2 Camera Picture Signal Input - One or both of the camera input connectors can be used to connect to the cameras. (dc+ power supply to the cameras is fed through these connectors).

2. DC 12-24 Volt Power Supply Leads - Ensure the wires are connected correctly to prevent damage. Connect the Red wire with fuse holder to an ignition switched positive feed, Yellow wire (trig1) to the reverse gear switch (+ve) and the Black wire to the vehicle chassis ground (negative earth systems only). Blue wire (trig 2) can be used if necessary.

Note: If the cigarette power lead is not being use, a suitable 2amp fuse must be placed in the positive supply line.

## ASPECT RATIO

Setting 1: 4:3 Normal Screen Size  
Setting 2: 16:9 Wide screen / Zoom

## REMOTE CONTROL



1. Power
2. V1/V2 Change
3. Positive Increase
4. Menu
5. Negative Decrease
6. Mode selection

# SYSTEM CONNECTION DIAGRAM

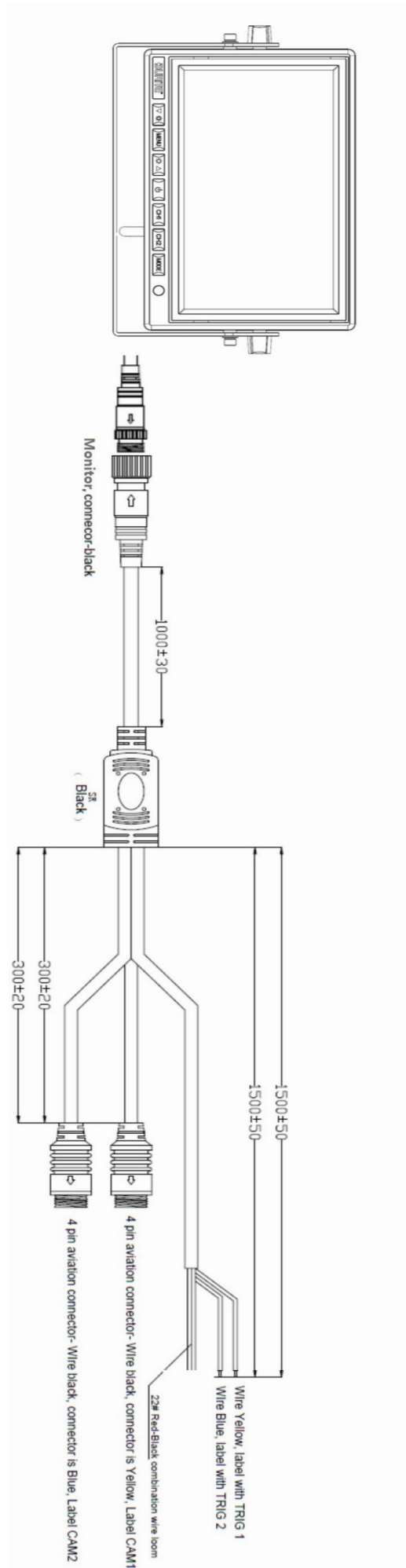



## TECHNICAL SPECIFICATIONS

Display Device	7" Split Screen Colour TFT LCD
Interface	Digital TTL
Resolution	800 x RGB x 480
Luminance (Nits)	500
System	PAL / NTSC (Auto)
Contrast Ratio	500:1
Power Consumption	5W
Power Supply	12/24VDC
View Angle	L 70°, R 70°, U 60°, D 70°
Connection	Male 4 PIN Aviation
Operating Temperature	-20°C to +70°C
Weight	500g
Dimensions	L 180 x W 20 x H 135mm
Type	1/3" Sony CCD
Voltage	12VDC
Sensitivity	0 LUX with IR on
S/N Ratio	48dB
Current Draw (at 12V)	200mA
Electronic Shutter	Auto
Lens	f 2.8mm
View Angle	Horizontal @ 120°, vertical @ 95°
Video Output	1 Vpp, 75 Ohm
IP Rating	IP68
Auto Gain Control	Yes
Microphone	Yes
Weight	360g
Dimensions	L 84 x W 76 x H 70mm
Operating Temperature	-20°C to +70°C
Certificates	ECE R10.05

## TECHNICAL DRAWING

