

auto electrical parts

Technical Information Sheet

Part No. 0-171-75

12/24 volt Red rear marker lamp with 2 LED's, halo rings and reflex reflector. Protected to IP67. ECE approved. E Marked

Additional Information:

Supporting Bracket Part No. 0-171-98 as shown in the below technical drawing.

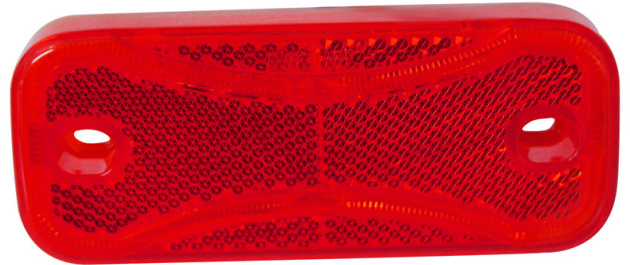

Technical Drawing (not to scale)

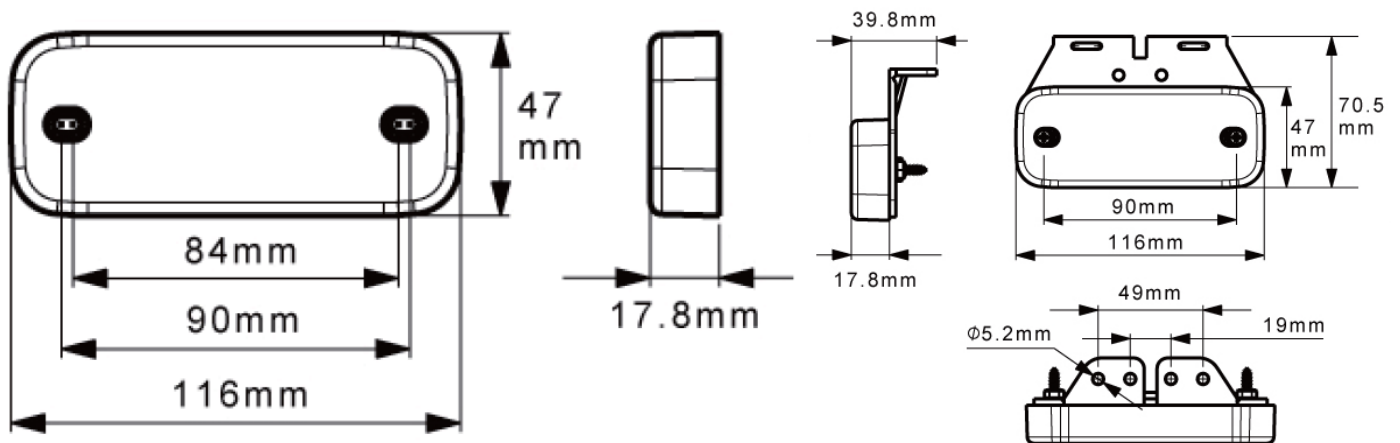

Specification

Type	LED Marker Lamp
Voltage rating	10-30VDC
Material	ABS Housing, PC Lens
LEDs	2 x SMD LED's
Current Draw	0.05A @ 12.5VDC
Fly Leads	50cm
Dimensions	Please see above diagram
Protection	IP67
Approvals	E Marked, ECE R7, R3

The information contained in this document is correct to the best of our knowledge at the time of printing. However, specifications may change at any time without notice.