

auto electrical parts

Technical Information Sheet

Part No. 0-420-48

Durite's powerful 16 x 3 watt 12/24 volt LED work / reverse lamp. Flood/Spot Combo Beam. Low current draw 1.0 amp at 12 volt dc. Black powder coated die cast aluminium case, polycarbonate lens, supplied with stainless steel bracket and 300mm flying lead. Protected to IP69k. I 109 x w 41 x h 135mm. ECE R10 approved for EMC. ECE R23 approved for Reversing.



Technical Drawing (not to scale)

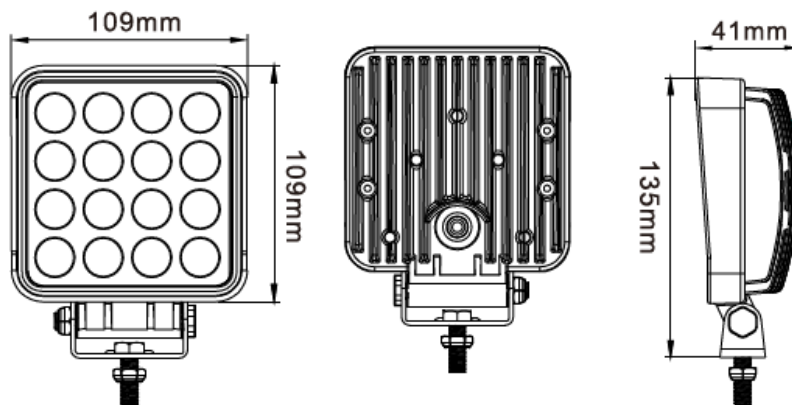

Specification

Type	LED Work / Reversing Lamp
Voltage	10-30VDC
Current	1.0A @ 12VDC
LEDs	16 x 3W (48W Total)
Light intensity	1600 Raw Lumens, 820 Effective Lumens
Housing	Aluminium
Bracket	Stainless Steel
Lens	PC
Degree of protection	IP69K
Operating temperature	-45°C ~ 60°C
Weight	0.330Kg
Dimensions	Please see above diagram
Compliance	ECE EMC R10, R23 Reversing, RoHS

The information contained in this document is correct to the best of our knowledge at the time of printing. However, specifications may change at any time without notice.