

auto electrical parts

Technical Information Sheet

Part No. 0-420-79

A powerful 12 x 3 watt 12/24 volt LED work lamp. Black powder coated die cast aluminium case, PMMA lens, supplied with magnet base, handle, switch, cable and cigarette plug. Protected to IP67. I 140 x w 70 x h 140mm.

Additional Information

If an extension cable is required please use **0-601-55**: retractable cable 2.45m working length.



Technical Drawing (not to scale)

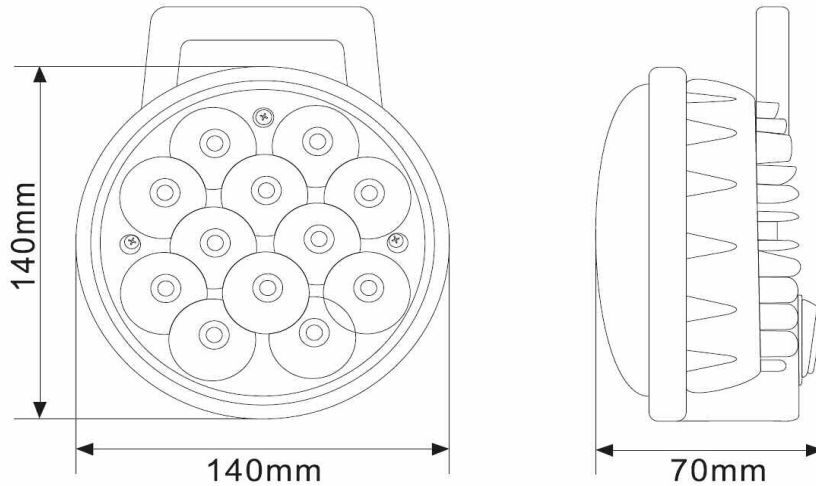

Specification

Type	LED work lamp
Voltage	10-30 volt dc
LEDs	12 x 3W Epistar LEDs
Light intensity	approx. 2600 lumens
Color Temperature	6000K
Housing	Die cast aluminium
Bracket	Stainless steel
Lens	PMMA
Degree of protection	IP67
Operating temperature	-40°C to +60°C
Weight	940g
Dimensions	I 140 x w 70 x h 140mm

The information contained in this document is correct to the best of our knowledge at the time of printing. However, specifications may change at any time without notice.