

auto electrical parts

Technical Information Sheet

Part No. 0-420-96

Durite's LED driving lamp. A powerful 60 watt (12x5W) 5400 Lumen, 12/24volt LED Work lamp. Black powder coated die cast aluminum case, polycarbonate lens. Protected to IP68. 30cm Flying Leads. Approx Life: 50,000 hours. E Marked R10 EMC, R112.



Technical Drawing (not to scale)

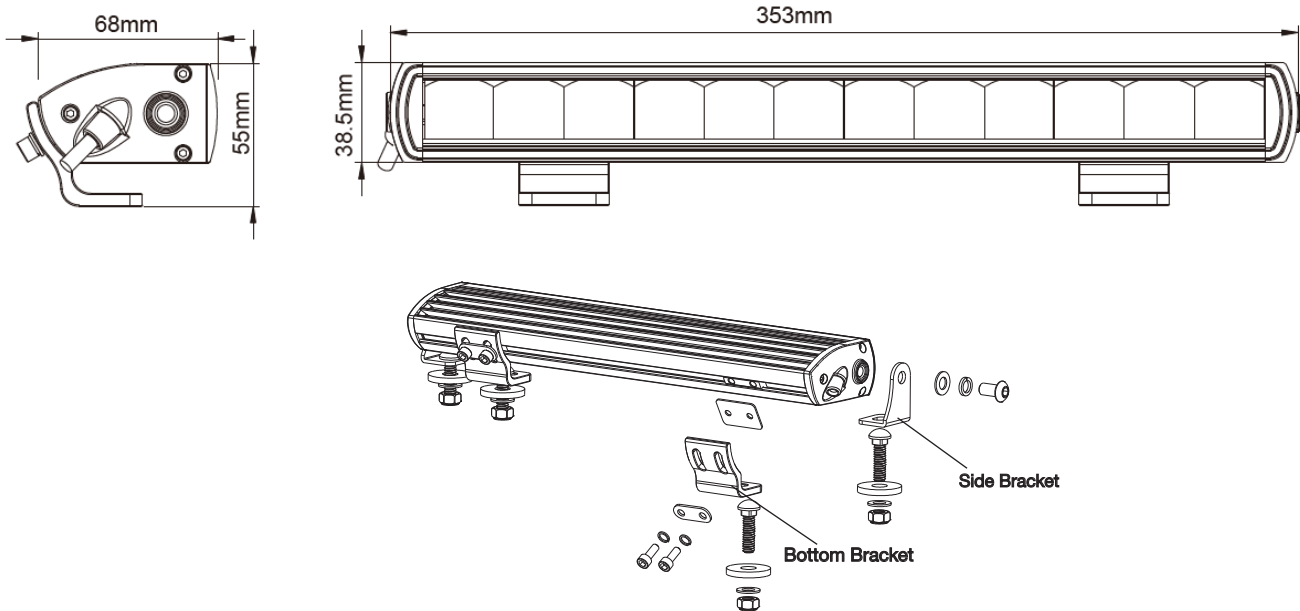

Specification

Type	LED Driving Lamp
Voltage	9-36 volt dc
Current Draw	3.8A @ 12VDC. 1.66 @ 24VDC
LEDs	ETI 12 x 5W (6500K)
Lumens	5400Lm
Housing	Die cast aluminium
Bracket	SS304
Lens	Polycarbonate
Degree of protection	IP68
Operating temperature	-40°C to +60°C
Weight	1.5Kg
Dimensions	h 55 x w 353 x d 68mm
Approval	CE, EMC R10, R112

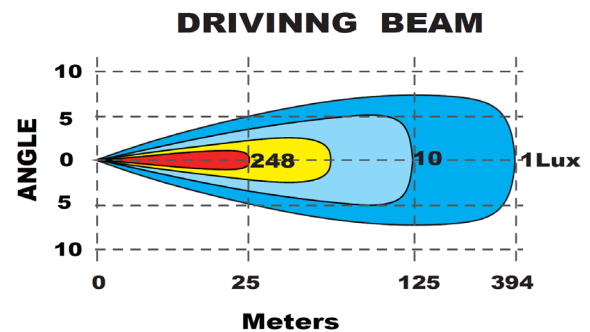

The information contained in this document is correct to the best of our knowledge at the time of printing. However, specifications may change at any time without notice.