

auto electrical parts

Technical Information Sheet

Part No. 0-442-11

High intensity, amber LED horizontal warning light with black aluminium housing. 12/24 volt 3 amber LED unit with 12 flash patterns. ECE R65 approved. Protected to IPX8.

Additional information

Red wire +ve supply
 Black wire -ve ground
 White wire alternating flash
 Yellow wire synchronization and flash pattern



Momentarily connecting the yellow wire to red changes the flash pattern, sequencing it through the 12 patterns, connecting it 3 times in quick succession resets the flash pattern to default (sequencing). Connecting the yellow wires together synchronizes the lights provided they have been set to the same flash pattern. Connecting one white wire to red will alternate the flash pattern of a pair of lights.

Technical Drawing (not to scale)

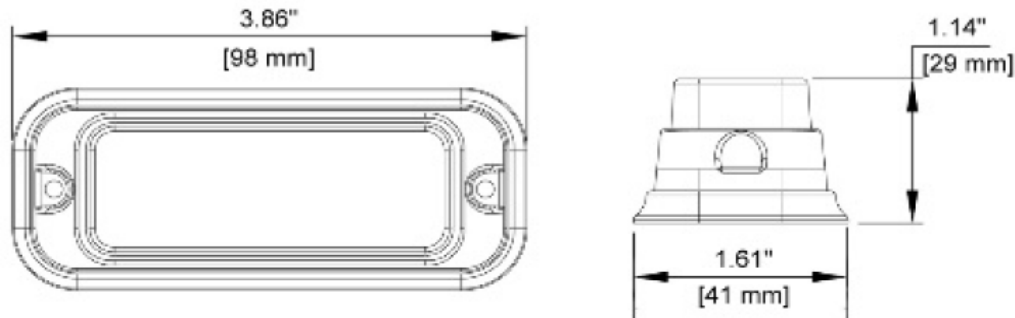

Specification

Type High intensity LED warning light
 Colour Amber
 Number of LEDs 3
 Voltage 12v, 24v
 Current 0.58 Max amps at 12v, 0.52A Average
 Flash patterns 12
 Base Aluminium
 Operating temperature -30°C to +60°C
 Protection IPX8
 Weight 83g
 Dimensions Please see above diagram
 Compliance CE, ECE R65

No.º	Flash Patternº	No.º	Flash Patternº
0º	Random (all)º	6º	Quadº
1º	Steadyº	7º	Quintº
2º	Single (R65)º	8º	8 Flashº
3º	Megaº	9º	Single - Quadº
4º	Doubleº	10º	Single H/Lº
5º	Tripleº	11º	Single-Triple-Quintº

The information contained in this document is correct to the best of our knowledge at the time of printing. However, specifications may change at any time without notice.