

auto electrical parts

Technical Information Sheet

Part No. 4-445-06

Durite Beacon. LED, 12/24VDC Single Bolt Mount. Green Lens. IP55. Double, Six and Rotating Flash. ECE R10.

Additional Information:

To select flash pattern remove lens by turning anti clockwise and select flash pattern by choosing the appropriate dip switch.

1. Rotating Flash
2. Six Flash
3. Double Flash



Technical Drawing (not to scale)

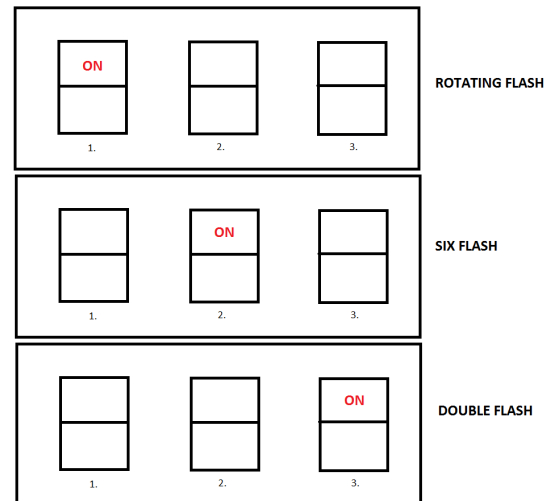
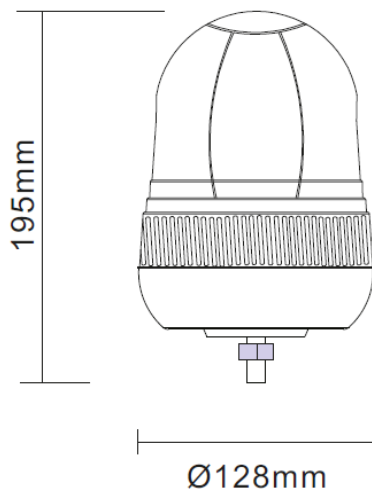

Specification

Type	LED Beacon Single Bolt
Voltage rating	12/24V (DC)
Power	9W
Current	0.75A @ 12VDC
No. Of LED's	40
Operating temperature	-30 / +50 °C
Lens material	PC
Dimensions	See above diagram
Approvals	E Mark ECE EMC R10
Protection	IP55

The information contained in this document is correct to the best of our knowledge at the time of printing. However, specifications may change at any time without notice.