

auto electrical parts

Technical Information Sheet

Part No. 0-767-60

Rear lamp, 12/24 volt LED, stop/tail/indicator, supplied with 500mm flying leads. 95mm dia, 2 x M8 fixing bolts. Acrylic lens and polycarbonate housing. ECE approved. Protected to IP67.

Additional information

Red wire Stop
Brown wire Tail
Green wire Indicator
White wire Ground/negative

A black bezel, part 0-767-97, is available 30mm deep.



Technical Drawing (not to scale)

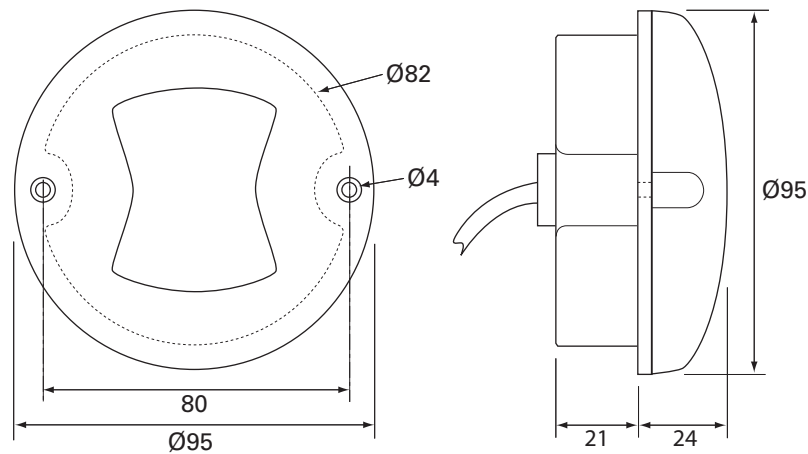

Specification

Type	LED rear lamp
Function	Stop/Tail/DI
Voltage	10 - 30 volt dc
Power	Stop 2.2 watt Tail 0.8 watt Indicator 1.7 watt
Lens	PMMA
Body material	ABS/polycarbonate
Lead	400mm
Operating temp	-40°C to +50°C
Weight	360g
Dimensions	See diagram above
Protection	IP67
Compliance	ECE

The information contained in this document is correct to the best of our knowledge at the time of printing. However, specifications may change at any time without notice.

Gordon Equipments Limited

Durite Works
Valley Road
Dovercourt
Essex CO12 4RX
England



Tel: +44 (0)1255 555200
Fax: +44 (0)1255 555222
E-mail: sales@durite.co.uk
Web: www.durite.co.uk

Registered in England at address shown No. 373113
The words 'Gordon', 'Durite', 'Nolten' and 'Acfil' are registered trade marks